

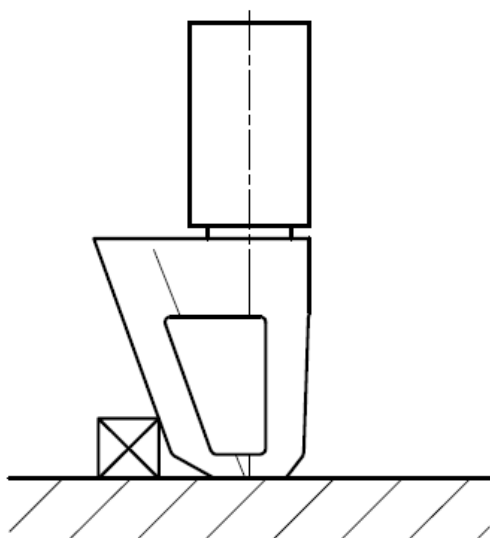

## 柄较短时

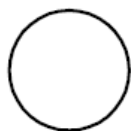

应垂直倒立放置干燥并保持至完全干燥



水平面

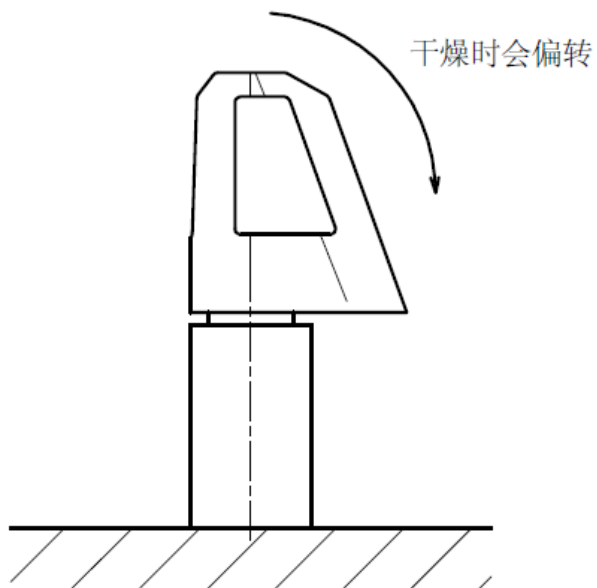

正立放置干燥时会因油嘴自重造成小角度偏转



## 柄较长时



- “ 铁柄较长时应水平放置粘接
- “ 最好两个同时粘，两端用治具固定